



# Development of deep placement fertiliser applicator and modelling of loads arising in the process of its operation

VAITEKHOVICH IURII<sup>1\*</sup>, BOIARSKII BORIS<sup>2</sup> AND HASEGAWA HIDEO<sup>3</sup>

<sup>1</sup>Graduate School of Science and Technology, Niigata University, 950-2181, Niigata, Japan

<sup>2</sup>Field Center for Sustainable Agriculture, Faculty of Agriculture, Niigata University, 959-1701, Niigata, Japan

<sup>3</sup>Institute of Science and Technology, Niigata University, 950-2181, Niigata, Japan

\* CORRESPONDING AUTHOR: yuriyv.a.94@gmail.com

## Data of the article

First received : 17 October 2023 | Last revision received : 23 November 2023

Accepted : 24 December 2023 | Published online : 28 December 2023

DOI : 10.17170/kobra-202307218423

## Keywords

modelling; agricultural machinery; cad; apm fem; deep placement fertiliser applicator

The article discusses the benefits of minimum tillage, which involves loosening soil and applying fertiliser below the main crop. This method reduces the number of operations needed to cultivate row crops like soybeans, wheat, and others. The soil tillage research, namely the mathematical calculation and static analysis performed using the CAD system, revealed the loads that arise directly in the places where the soil deepener is attached to the supporting structure's frame. Moreover, it also shows all the points that can be subjected to loads, such as the back of the deep tillage stand, the attachment point of the arrow-shaped coulter, and including spreader plate used for wide fertiliser delivery. Based on mathematical calculations, the calculated loads for soil deepeners were 2500 N per tool. CAD modelling enabled us to determine the form and details of the working tool, analyse the design integrity, identify structural deformations, and determine important indicators such as maximum load and safety factors. The obtained values indicate that the selected materials and fastening methods will satisfy the operating conditions obtained by calculation.

## 1. Introduction

Developing new crop technologies and practices is one of the most important roles in sustainable agriculture. For this purpose, farmers in developing countries are looking for new technologies to increase the labour economy, crop yields, and crop quality by reducing the amount of fertilisers used. In addition, it should reduce environmental damage to the atmosphere and water (Fujii, Hasegawa, Ohyama, & Sinegovskaya, 2015a; Walsh et al., 2020).

In the production of any crop, the main operations are pre-sowing tillage, application of necessary fertilisers, sowing, and care of the crops. Usually, fertilisers are applied according to the NPK nutrition scheme (Man,

Deen, Dunfield, Wagner-Riddle, & Simpson, 2021) (Man, Deen, Dunfield, Wagner-Riddle, & Simpson, 2021), but this is not enough. Mineral fertilisers are also used to a greater extent than organic fertilisers. Although organic fertilisers contain various additional substances. Which are also involved in the formation and feeding of plants (Rozhkov et al., 2022). In addition, it is necessary to understand how to apply fertilisers.

Nowadays, the field of agriculture has employed different techniques for the application of substances to plants. The previous studies use either a variant of surface application, scattering over the field (He,

Luo, Duan, Kong, & Tang, 2022), or application at depth together with the seeds of plants (Walsh et al., 2020). However, the option of applying fertilisers to a depth below the level of soybeans is not widely used (Lourenzi et al., 2021). In the current agricultural landscape, a significant focus is placed on enhancing soil fertility and augmenting crop yields (Rychel et al., 2020; Wu, Li, Fipps, Zhang, & Yu, 2021). This is particularly challenging in the face of the widespread use of plant protection products and herbicides (Pryvedeniuk, Kutsyk, & Hlushchenko, 2021). Modern agriculture is exploring various techniques to achieve this goal sustainably, including alternative approaches to chemical-based farming (Balkrishna et al., 2023; Ohyama et al., 2022), innovative crop management strategies (Fountas et al., 2015), and precision agriculture technologies (Boiarskii, Hasegawa, Sinegovskii, & Boiarskaia, 2019; Sishodia, Ray, & Singh, 2020; Zhang, Wang, & Wang, 2002).

Solving the problem of increasing soil fertility and increasing the yield of crops, new technologies for their cultivation are being developed, such as deep-placement fertiliser applicators (Fujii, Hasegawa, Ohyama, & Sinegovskaya, 2015b; Takahashi, Chinushi, Nagumo, Nakano, & Ohyama, 1991; WANG et al., 2020). This tool is designed to deliver fertilisers directly into the root level, maximising nutrient uptake and minimising waste (Ohyama et al., 2022; Patuk, Hasegawa, Borodin, Whitaker, & Borowski, 2020; Tewari et al., 2007). By allowing farmers to apply fertilisers efficiently, this technology can help protect the environment, improve crop quality, and soil fertility, and increase overall productivity (Ohyama et al., 2022; Patuk & Borowski, 2020; Tewari et al., 2011).

However, the successful implementation of this technology requires a thorough understanding of the structural dynamics of agricultural machines to ensure their effectiveness and reliability (Patuk et al., 2020). To address the challenge of reducing study and testing time, computer-aided manufacturing systems (CAD systems) are increasingly being employed, particularly the strength analysis system (APM FEM) module. These tools enable researchers and farmers to design, simulate, and optimise their agricultural machines before physical testing, streamlining the production process and boosting productivity (Allagui, Belhadj, Aifaoui, Hammadi, & Choley, 2021; Patel, Moses, D'souza, & Aalam, 2022; Singh et al., 2022;

Zeng, Chen, & Zhang, 2017a).

In the study, a CAD system was used to design and analyse a specialised tool of the deep-placement fertiliser applicator, consisting of a soil deepener stand and seeding coulter. This research aims to enhance crop yields by refining the fertiliser application process to a depth below the sowing level. The structural strength of the deep tillage tool was evaluated through static analysis using APM FEM. This analysis showed crucial strength characteristics, including safety margins and material stresses, enabling the identification of weak points, specifically, the maximum and minimum load points susceptible to deformation that might affect structural and material integrity during the operational use of the deep tillage tool with a tractor. Based on the calculations, the values obtained suggest that the chosen materials and fastening techniques will be adequate to meet the required operating conditions. Additionally, the study assessed the impact of technological processes, technical means, and fertiliser application methods, contributing valuable insights to advancing sustainable and efficient agricultural practices.

## 2. Materials and methods

### 2.1 Method of soil deepening and fertilising

Based on our review and practical use of previous applicators we concluded that fertilisers are placed in depth limited by line (Patuk & Borowski, 2020; Patuk et al., 2020). Moreover, fertilisers tend to be dropped to a deeper depth than planned followed by a chisel plough, since a sowing hose is installed right after the chisel (Patuk & Borowski, 2020; Patuk et al., 2020). Thus, we considered placing arrow-shaped coulter with plate under the fertilisers placement depth to ensure the proper depth of fertilisers and spreading widely by each row.

This study proposes a new method of pre-sowing tillage using a soil deepener followed by sowing by seeding coulter. The method is designed to reduce the load on the soil by combining three operations - soil deepening and placement fertilisers to depth, as well as pruning the roots of weeds with deep loosening of the soil to create a favourable environment for the growth and development of the main crop (Ohyama et al., 2017; Potratz et al., 2020). Deep placement fertiliser

technology (DPFT) serves not only to reduce losses and overuse of fertilisers, but also to distribute nutrients evenly in the soil and mitigate the negative environmental impact of fertilisers (Ohyama et al., 2017; Patuk, Hasegawa, Borowski, Borodin, & Lyude, 2018).

The method of cultivating crops, including sowing, and application of fertilisers in the row, can be carried out both on stubble or in the ploughed field. In the row of the crop, simultaneous tillage with fertiliser application is carried out at a depth that can be reached

by the plant roots, for example for soybeans in the first trifoliate stage (V1) (Fehr & Caviness, 1977). At the same time, the sowing row can be shifted every sowing season according to the size of the width of the seeding row, to maximize soil effectiveness. The proposed scheme, based on previous research (Patuk et al., 2020; Zeng, Chen, & Zhang, 2017b), of deep placement fertiliser applicator is shown in Figures 1 and 2. The same method was described in (Osipov Ya.A., Vaitekhovich Yu.A., Epifantsev V. V., & Panasyuk A.N., 2021).

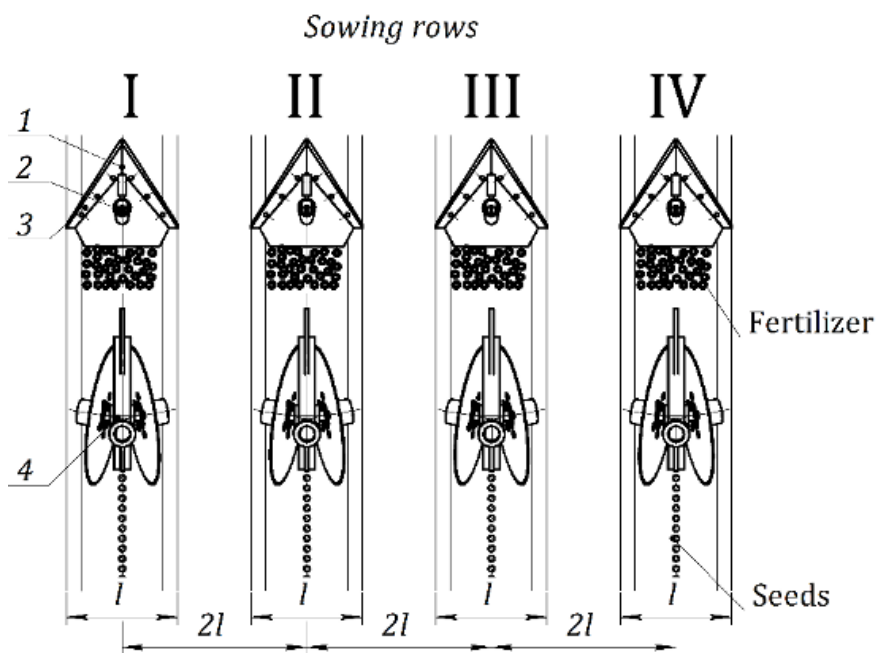

**Figure 1.** The top view of four rows scheme of fertiliser application using soil deepener and soybean sowing utilising seeding coulters. 1- deep tillage stand, 2 - fertiliser hose, 3 – arrow-shaped coulters, 4 - seeding coulters.

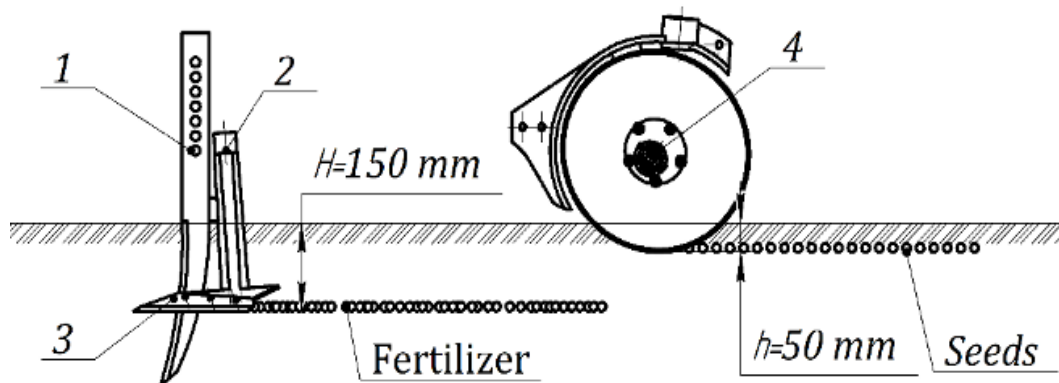

**Figure 2.** The side view of the scheme of fertiliser application using soil deepener and soybean sowing utilising seeding coulters. 1- deep tillage stand, 2 - fertiliser hose, 3 – arrow-shaped coulters, 4 - seeding coulters.

By employing this pre-sowing tillage method, the following benefits can be obtained:

1. Using the soil deepener stand as a knife, an incision of at least 25 cm depth and 2 cm width is made in the soil, allowing for a systematic drainage and supply of moisture to the roots.
2. Using the arrow-shaped knife as a coulter will cut the roots of weeds and loosen the soil at depth. Fertiliser application using this coulter can increase the nutrient availability area for soybeans and help contribute to their growth and development.
3. Organic granular fertilisers decompose within all stages of growth. In combination with strip application, there is no need to apply fertiliser all over the field every year, farmers only need to apply it to the sowing strip, which is shifted by the width of the coulter every season.
4. After two agricultural seasons of applying pre-sow-

ing tillage with simultaneous deep fertilisation, it is recommended to bring up a deep layer of soil to the top. This layer is saturated with micro- and macroelements, which provide plant nutrition in subsequent seasons. Also, by this method, we ensure the restoration of the fertile soil layer.

## 2.2 Development of deep tillage tool scheme

Based on the studies carried out in the field of minimal tillage (Barr, Desbiolles, Fielke, & Ucgul, 2019; Nunes, Denardin, Pauletto, Faganello, & Pinto, 2015), a scheme of the working tool of the soil deepener is proposed, which includes soil deepening, soil treatment at depth, application of an additional dose of fertiliser to a depth below the level of sowing of the main crop, to ensure plant nutrition, as well as recover soil fertility. In order to carry out the work outlined in the pre-sowing tillage method, a scheme of the working tool was devised for the agrotechnical operations discussed above. This scheme is illustrated in Figure 3.

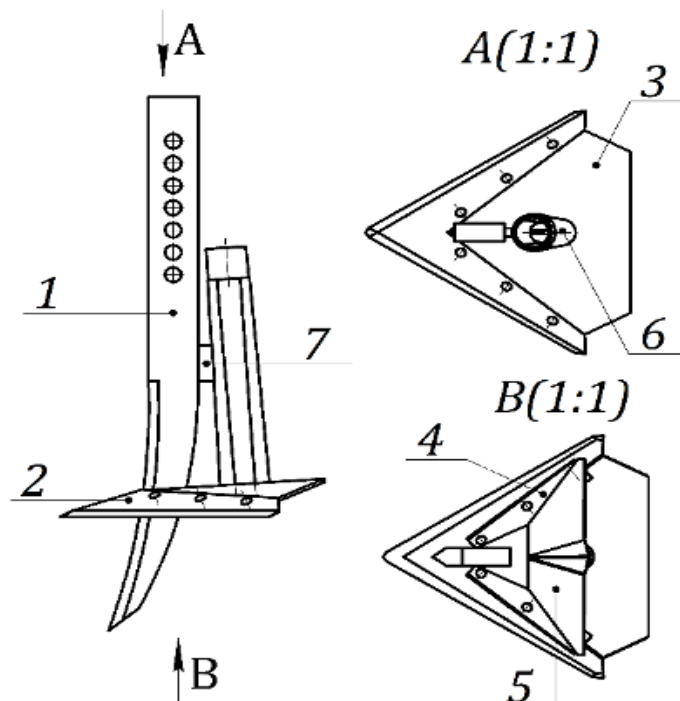

**Figure 3.** Scheme of the soil deepener tool for fertiliser application on the depth. A – top view. B – bottom view. 1- soil deepener stand, 2 – arrow-shaped coulter, 3 - shoe plate, 4 - mounting plate, 5 - spreader plate, 6 - fertiliser hose, 7 – connector.



The soil deepener stands 1 is attached to the sowing section through connector 7. The arrow-shaped coulter 2, cutting the soil layer and producing its loosening, simultaneously destroys weeds, and shoe plate 3 prevents the soil from crumbling before placing fertilisers. Fertilisers, moving along the fertiliser hose 6, due to the inclination of its upper part forward, without changing the trajectory and direction of movement, fall on the spreader plate 5, fixed in the lower part of the shoe plate 3. After that, fertilisers can be widely and evenly spread, providing an optimal area for plant nutrition.

Parameters describing agrotechnical requirements for the deep tillage tool were selected following agrotechnical requirements for the operations that are combined in this working tool (soil deepening, soil loosening, fertiliser application, sowing width, and others) and the method of cultivation of crops (Osipov Ya.A. et al., 2021; Patuk et al., 2020). The loosening depth is chosen because of studies conducted in the field of soil compaction by machine-tractor unit (Panasyuk & Lipkan, 2020). The parameters required for the construction of a model of the soil deepener and the mathematical calculation of the tractive effort of the implement in action (Table 1).

Soil deepener depth indicates the desired depth for cutting into the soil during the deepening process. A depth of 25 cm has been specified, which suggests a substantial penetration to address soil compaction (Hewitt, Balestri, Lo, & Watson, 2019). Fertiliser width specifies the width of the area where fertilisers are spread. The 20–27 cm range suggests flexibility in accommodating different spreading patterns, possi-

bly applied to specific crops or agricultural practices. The cultivation depth of 12 cm indicates the depth to which the soil will be loosened during the cultivation process. This is a moderate depth, suitable for promoting optimal soil aeration, pruning the roots of weeds, and crop root development.

### 3. Results and discussion

#### 3.1 Mathematical calculation of the tractive force of the implement in action

##### 3.1.1 Distribution of forces affecting the operation of a tractor with an agricultural machine

To understand the effect of forces on the tractor's towing device when working with a subsoiler installed on it, a diagram is presented indicating the acting forces that affect the operation of the tractor-machine (Fig. 4).

In the presented diagram in Figure 4, we see the main operating loads during the operation of a tractor with a subsoiler, such as friction force ( $F_{Tp}$ ), tractor traction force ( $F_T$ ) and operating speed ( $V_p$ ). In this case, these forces are necessary to further calculate the traction force generated on the tractor hook. Since they are the main ones during its operation and influence the choice of tractors for working with agricultural implements.

##### 3.1.2 The mathematical calculation of the tractive force when using a deep tillage tool

Before carrying out the static analysis, the applied forces were calculated based on the diagram of the

**Table 1.** Set of agrotechnical requirements for a deep tillage tool, specifically focusing on parameters related to soil deepening equipment.

Parameter	unit [cm]
Soil deepener depth (depth of soil cutting)	25
Fertilisers width (the area where fertilisers are being spread)	20–27
Cultivation depth (soil loosening depth)	12
Diameter of hose (standard diameter of fertilisers hose)	5
Depth of fertiliser application from the depth of seeding (the range varies based on the time and depth of root germination)	From 5 to 15

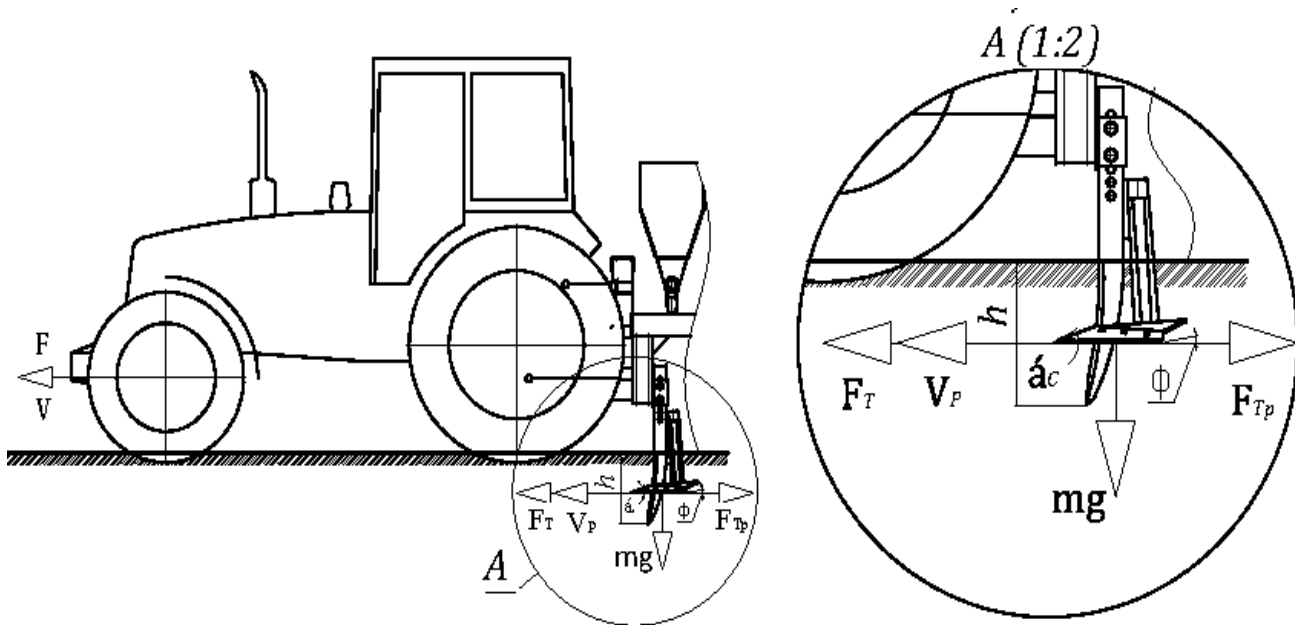

**Figure 4.** Force distribution diagram for tractor operation with Deep tillage tool

application of forces during the operation of the tractor-implement on the field. The forces involved in the calculation are considered for the correct assessment of work and selection of the tractor traction class that will be used to work with agricultural machines. In the presented formula 1 and 2, we consider the interrelation of forces occurring during the operation of this tool in loamy soils (Rudenko N. E., 2014).

The traction resistance of the soil deepener with an arrow-shaped coulter is determined by the formula:

$$F_T = (Kb_t t_1 + Kb_l L \cdot \sin \alpha) \cdot (1 + \tan \varphi \cdot \sin \alpha) \cdot (1 + \tau(h - h_0)) \cdot (1 + \varepsilon(V_p - V_0)) + (b_l L \cdot \sin \alpha + t_c h) \cdot \rho_0 \cdot \left(\frac{V_p}{3.6}\right)^2 \quad (1)$$

After conversion, the formula will take the form:

$$F_T = Kb_t \cdot (t_1 + L \sin \alpha) \cdot (1 + \tan \varphi \cdot \sin \alpha) \cdot (1 + \tau(h - h_0)) \cdot (1 + \varepsilon(V_p - V_0)) + (b_l L \cdot \sin \alpha + t_c \cdot 0.01h) \cdot \rho_0 \cdot \left(\frac{V_p}{3.6}\right)^2 \quad (2)$$

where:  $t_c$  – width of the soil deepener strut – 0,02 m;  $p_0$  – the volumetric mass of soil – 1000 kg/m<sup>3</sup>;  $V_p$  – operating speed of the machine – 9 km/h (2.5 m/s);  $\varphi$  – the angle of friction of the soil on the surface of the arrow-shaped coulter - 26 degrees;  $\tau$  – machining depth coefficient – 0,08...0,1 cm<sup>-1</sup>;  $h$  – processing depth – 0,25 m;  $\varepsilon$  – the speed coefficient – 0.06...0,08 (km/h)-1;  $L$  – the width of the face of the ploughshare – 0.045 m;

$b_1$  – arrow-shaped grip width – 0,27 m;  $\alpha$  – the angle of crumbling of the ploughshare – 23 degrees;  $k$  – specific soil resistance – 35000 N/m<sup>2</sup>;  $t_1$  – width of the stand of soil deepener – 0,02 m.

The formula comprises several components representing various factors influencing traction resistance, including soil properties, machine speed, and design parameters. Variables are interconnected, representing the interaction between different aspects of the soil deepener design and operation. The second formula is a simplified version of the first, reducing redundancy and facilitating a clearer representation of the traction resistance calculation. In practical terms, these formulas provide valuable insights for engineers and researchers involved in designing and optimizing soil deepening equipment.

Under conditions of soil composition heterogeneity, deep layers compaction, and the appearance of stones in the area of the cultivation row, the resulting loads may change during the operation of this deep tillage tool. However, the theoretical calculation was carried out considering these conditions (Rudenko N. E., 2014). Based on the obtained values, the choice of metal, shape of parts and scheme of their fastening between each part will increase the efficiency of work and reliability of the structure as a whole, prevent possible deformations of the structure and reduce the

load on the tractor hitch.

Considering the calculation error, the obtained tractive forces of 2500 N indicate that these implements can be used with traction class 1.4 and higher, but for efficient and productive work, it is suggested to use this deep tillage tool with tractors of traction class 2 (Panasyuk & Lipkan, 2020). That will provide a power reserve for the applied tractor and ensure the correct joint operation of the proposed soil-deepening tool.

After carrying out a mathematical calculation of the load on the component parts, a model of the soil deepener was built in the CAD system. The soil deepener was designed with a shape that evenly distributes forces on the tip of the stand and over the shape of the knife of an arrow-shaped coulter, ensuring efficiency and reliability. In comparison with other models of this soil deepener, a significant difference is that they use fertiliser placement in a line, which allows for reduction of the load on the tool, but at the same time, fertiliser does not always remain at the specified depth (Patuk & Borowski, 2020; Patuk et al., 2020; Wang et al., 2020). In our version, although with a slight difference in the load, an arrow-shaped coulter is used, which in turn, thanks to the shape of the edge knife, loosens the soil and places fertiliser on the planned level. Thereby not creating excessive load on the tractor hitch and frame fasteners at the time of work.

Static analysis of the load was carried out using the data obtained in the mathematical calculation. Static analysis was carried out with the application of two load variants: 2500 and 5000 N. The choice of loads was made since the path of the tractor soil compacted even in the ploughed field (Wang et al., 2020). Also, there are uncompacted clods of soil after its treatment, which in turn creates additional forces during the operation of a machine-tractor unit (especially at a depth below 150 mm).

### 3.2 Static analysis of a deep tillage tool

We conducted a static analysis using the APM FEM module. When modelling soil-deepening equipment, we used standard materials such as steel 10 State All-Union Standard 1050-2013 or its equivalent, steel AISI 1010. We optimized the model of a deep placement fertilizer tool to reduce its weight and increase

its service life using CAD module FEM. We based our findings on several studies published on developing applicators and subsoilers for deep fertilization (Ahamed, A. T. M. Ziauddin, & Sarker, 2014; Hoque, Wohab, Hossain, Saha, & Hassan, 2013; Kostencki, Stawicki, & Królicka, 2021; Osipov Ya.A. et al., 2021; Patuk & Borowski, 2020; Patuk et al., 2020).

The importance of determining the strength coefficient and the stresses occurring in the metal is due to the fact that in case of incorrect material selection, significant metal deformation may occur in the deep loosener parts, which will subsequently affect the traction resistance of the tractor or may lead to significant breakage of the implement. Stresses occurring in the metal can significantly affect the service life of the implement and its safe use.

Simulation of the working process with calculated loads showed that the main stress in the metal occurs directly at the point of attachment of the soil deepener. Additionally, high stress is observed in the backside of the tool. In Figure 5 (a, b), the stresses in the metal are highlighted in colours ranging from blue (10) to red (0) at loads of 2500 N and 5000 N. Figure 5 shows the load distribution of the deep tillage tool. The susceptible areas are prone to deformation and metal destruction which reduces its durability. The lower part of the knife and arrow-shaped coulter have an insignificant load. The load is evenly distributed on the back part of the stand, indicating that the material and shape of the tool are correct. These findings should be considered when designing the mounting points of the deep tillage tool.

Our study indicates that the safety factor ranges from 2 to 10 points, with the lowest value at the top of the stand where it is directly attached. This suggests that the metal is susceptible to deformation and fatigue. However, the average strength factor of 5 points suggests that there is a low risk of deformation and fracture, which generally indicates high durability and uptime. Moreover, the use of metal ensures that any repairs can be made, even in field conditions.

The main load is concentrated on the tip of the deepener, which is 2500 N as illustrated in Figures 5(a) and 6(a). The load distribution is visible in the simulation figure. The main load occurs at the attachment point

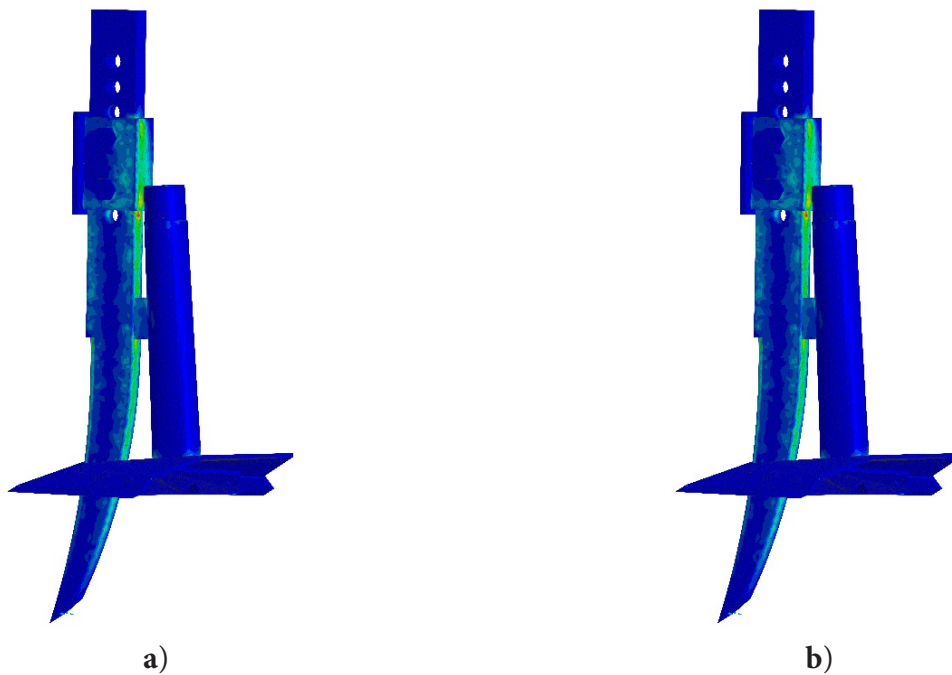

**Figure 5.** Load distribution on the Deep tillage tool  
a) 2500 N; b) 5000 N

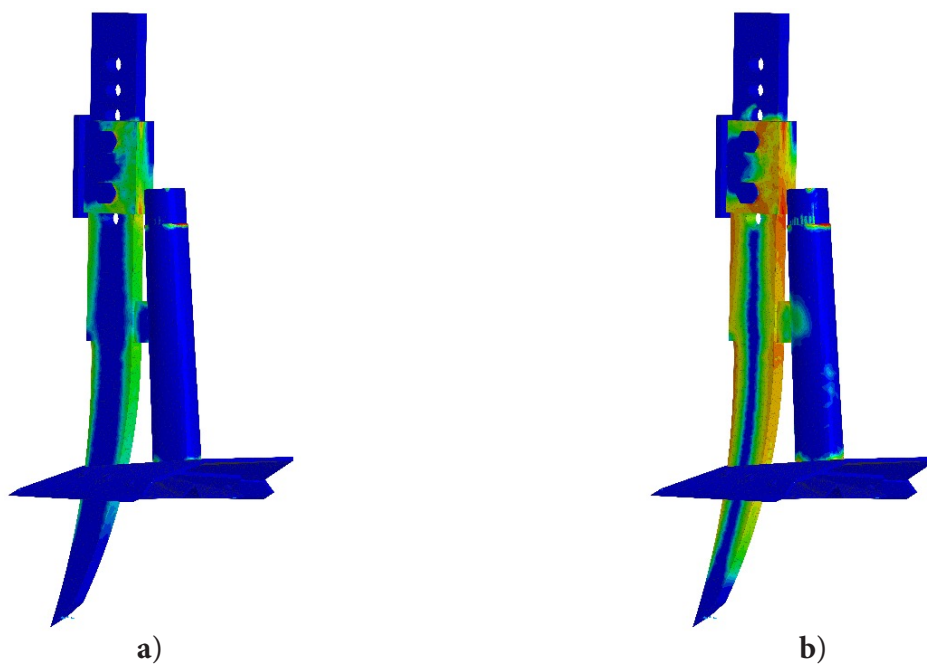

**Figure 6.** Deep tillage tools margin of safety (2500 N)  
a) 2500 N; b) 5000 N

of the soil deeper into the attachment of the working machine frame (Figure 6).

Due to its shape and fixing principle, the metal is less subject to deformation, and the safety margin of the

metal remains around 2 points. The main working area of the cultivator, namely its blade, retains a safety factor of around 5 points. Reliable fastening of the deep tillage tool, proper material, and interrelation of parts ensure work safety. Strength factor and traction



resistance determine possible failure areas and low traction class compatibility. Tool design achieves reliability and durability through mathematical and static analysis.

#### 4. Conclusions

The use of a CAD system for designing and analysing a specialized deep-placement fertiliser applicator tool, incorporating a soil deepener stand with arrow-shaped coulter, and seeding coulter, has been significant in improving agricultural practices. The use of a wide application of fertiliser to a depth below the level of sowing will provide additional nutrition during the flowering and bean-forming phase in soybeans. The use of soil tillage can regulate soil moisture by diverting excess humidity. The arrow-shaped coulter also prunes weed roots.

The structural integrity of the deep tillage tool underwent a detailed evaluation through static analysis, using the APM FEM module. The analysis revealed critical strength characteristics, including safety margins and material stresses, leading to the identification of vulnerable points—specifically, the maximum and minimum load points susceptible to deformation during the operational use of the tool with a tractor. Mathematical calculation determined the minimum traction required to use the soil deepener with a tractor. (For the 1st unit is equal to 2500 N). The outcomes of the structural analysis, based on the calculations, affirm that the selected materials and fastening techniques are deemed adequate to withstand the demanding operating conditions of the deep tillage tool. These findings ensure the tool's reliability and durability, crucial factors for its effective implementation in agricultural settings.

The next steps involve practical implementation by manufacturing the deep-placement fertiliser applicator based on verified design and material choices. This will help farmers with efficient and reliable fertiliser application, promoting environmentally friendly farming practices and enhancing crop yields.

#### Conflict of interest

The authors declare no conflict of interest. Besides, the funders had no role in the design of the study; in

the collection, analysis, or interpretation of data; in the writing of the manuscript, and in the decision to publish the results.

#### Data Availability Statement

The raw data and static analysis of a deep tillage tool are available from the corresponding author upon reasonable request.

#### Acknowledgements

We would like to express our gratitude for the financial support provided by the Ministry of Education, Culture, Sports, Science and Technology (MEXT).

#### References

- Ahamed, M. S., Ziauddin, A. T. M., & Sarker, R. I. (2014). Design of improved urea super granule applicator. *International Journal of Applied Science and Engineering Research*, 3(1). doi: 10.6088/ijas-er.030100010
- Allagui, A., Belhadj, I., Aifaoui, N., Hammadi, M., & Choley, J. Y. (2021). A CAD-System engineering interoperability by Enriching CAD database with functional information. *18th IEEE International Multi-Conference on Systems, Signals and Devices*, 2021. doi: 10.1109/SSD52085.2021.9429313
- Balkrishna, A., Arya, V., Bhat, R., Chaudhary, P., Mishra, S., Kumar, A., Sharma, V., Sharma, V., Sharma, N., & Gautam, A. K. (2023). Organic farming for sustainable agriculture and public health: Patanjali's perspective. *Vegetos*. doi: 10.1007/s42535-023-00717-y
- Barr, J. B., Desbiolles, J. M. A., Fielke, J. M., & Ucgul, M. (2019). Development and field evaluation of a high-speed no-till seeding system. *Soil and Tillage Research*, 194, 104337. doi: 10.1016/j.still.2019.104337
- Boiarskii, B., Hasegawa, H., Sinegovskii, M., & Boiarskaia, A. (2019). Application of UAV and multispectral camera for field survey in the Amur Region, Russia. *CEUR Workshop Proceedings*, 2426, 83–89.
- Fehr, W. R., & Caviness, C. E. (1977). Stages of Soybean Development- Special report 80. Retrieved from

<https://dr.lib.iastate.edu/bitstreams/13bd0d8f-66ff-4d0e-a0e3-a70c2c47f6f3/download>

Fountas, S., Carli, G., Sørensen, C. G., Tsiropoulos, Z., Cavalaris, C., Vatsanidou, A., Liakos, B., Canavari, M., Wiebensohn, J., & Tisserye, B. (2015). Farm management information systems: Current situation and future perspectives. *Computers and Electronics in Agriculture*, 115, 40–50. doi: 10.1016/j.compag.2015.05.011

Fujii, T., Hasegawa, H., Ohyama, T., & Sinegovskaya, V. T. (2015). Evaluation of tillage efficiency and power requirements for a deep-placement fertilizer applicator with reverse rotational rotary. *Russian Agricultural Sciences*, 41(6), 498–503. doi: 10.3103/s1068367415060233

He, L., Luo, H., Duan, M., Kong, L., & Tang, X. (2022). Mechanized Hybrid Rice Seed Production: Planting Density, the Flight Height of an Unmanned Aerial Vehicle, Fertilizer Application, and the Row-Ratio of Parents. *Agronomy*, 12(7), 1572. doi: 10.3390/agronomy12071572

Hewitt, A., Balestri, F., Lo, M., & Watson, G. (2019). Species variation in root tolerance of soil compaction and poor drainage. *Arboriculture and Urban Forestry*, 45(6), 254–258. doi: 10.48044/jauf.2019.021

Hoque, M. A., Wohab, M. A., Hossain, M. A., Saha, K. K., & Hassan, M. S. (2013). Improvement and evaluation of Bari USG applicator. *Agricultural Engineering International: CIGR Journal*, 15(2), 87–94.

Kostencki, P., Stawicki, T., & Królicka, A. (2021). Wear of the working parts of agricultural tools in the context of the mass of chemical elements introduced into soil during its cultivation. *International Soil and Water Conservation Research*, 9(2), 229–240. doi: 10.1016/J.ISWCR.2020.11.001

Lourenzi, C. R., Ceretta, C. A., Ciancio, N. H. R., Tiecher, T. L., da-Silva, L. O. S., De-Conti, L., Giroto, E., Ferreira, P. A. A., Vidal, R. F., Scopel, G., Marchezan, C., & Brunetto, G. (2021). Forms of nitrogen and phosphorus transfer by runoff in soil under no-tillage with successive organic waste and mineral fertilizers applications. *Agricultural Water Management*, 248,

106779. doi: 10.1016/J.AGWAT.2021.106779

Man, M., Deen, B., Dunfield, K. E., Wagner-Riddle, C., & Simpson, M. J. (2021). Altered soil organic matter composition and degradation after a decade of nitrogen fertilization in a temperate agroecosystem. *Agriculture, Ecosystems & Environment*, 310, 107305. doi: 10.1016/J.AGEE.2021.107305

Nunes, M. R., Denardin, J. E., Pauletto, E. A., Faganello, A., & Pinto, L. F. S. (2015). Mitigation of clayey soil compaction managed under no-tillage. *Soil and Tillage Research*, 148, 119–126. doi: 10.1016/j.still.2014.12.007

Ohyama, T., Ikebe, K., Okuoka, S., Ozawa, T., Nishiura, T., Ishiwata, T., Yamazaki, A., Tanaka, F., Takahashi, T., Umezawa, T., Ohshima, H., Kato, T., Maeda, Y., Saito, A., Higuchi, K., Ohtake, N., Takahashi, Y., Harada, N., & Ohkama-Ohtsu, N. (2022). A deep placement of lime nitrogen reduces the nitrate leaching and promotes soybean growth and seed yield. *Crop and Environment*, 1(4), 221–230. doi: 10.1016/j.crope.2022.09.002

Ohyama, T., Tewari, K., Ishikawa, S., Tanaka, K., Kamiyama, S., Ono, Y., Hatano, S., Ohtake, N., Sueyoshi, K., Hasegawa, H., Sato, T., Tanabata, S., Nagumo, Y., Fujita, Y., & Takahashi, Y. (2017). Role of Nitrogen on Growth and Seed Yield of Soybean and a New Fertilization Technique to Promote Nitrogen Fixation and Seed Yield. In *Soybean - The Basis of Yield, Biomass and Productivity*. doi: 10.5772/66743

Osipov, Y. A., Vaitekhovich, Y. A., Epifantsev, V. V., & Panasyuk, A. N. (2021). Method for cultivation of row crops. Russian Federation: Federal Service on Intellectual Property. Retrieved from <https://patenton.ru/patent/RU2760938C1.pdf>

Panasyuk, A. N., & Lipkan, A. V. (2020). Calculation of the Ecological Thresholds of Normal Pressure of Machine Propulsion Drive in Working on Clay Soils. *Agricultural Machinery and Technologies*, 14(4), 43–48. doi: 10.22314/2073-7599-2020-14-4-43-48

Patel, A., Moses, S. C., D'souza, P. M., & Aalam, R. N. (2022). Design and Development of Sugarcane Leaf Stripper. *Bhartiya Krishi Anusandhan Patrika*, (1).



doi: 10.18805/bkap463

Patuk, I., & Borowski, P. F. (2020). Computer aided engineering design in the development of agricultural implements: a case study for a DPFA. *Journal of Physics: Conference Series*, 1679(5), 052005. doi: 10.1088/1742-6596/1679/5/052005

Patuk, I., Hasegawa, H., Borodin, I., Whitaker, A. C., & Borowski, P. F. (2020). Simulation for Design and Material Selection of a Deep Placement Fertilizer Applicator for Soybean Cultivation. *Open Engineering*, 10(1), 733-743. doi: 10.1515/eng-2020-0082

Patuk, I., Hasegawa, H., Borowski, P. F., Borodin, I., & Lyude, A. (2018). Modification of Seeder SZ-3,6 by using Deep Placement Fertilizer Application Technology. *Conference: The 9th International Symposium on Machinery and Mechatronics for Agriculture and Biosystems Engineering (ISMAB2018)*, 801–806.

Potratz, D. J., Mourtzinis, S., Gaska, J., Lauer, J., Arriaga, F. J., & Conley, S. P. (2020). Strip-till, other management strategies, and their interactive effects on corn grain and soybean seed yield. *Agronomy Journal*, 112(1), 72-80. doi: 10.1002/agj2.20067

Pryvedeniuk, N., Kutsyk, T., & Hlushchenko, L. (2021). The effect of main mineral fertilizers application and plants nutrition area on the quality of thyme raw plant materials (*Thymus vulgaris* L.) under irrigation conditions. *Agroecological Journal*, 2. doi: 10.33730/2077-4893.2.2021.234471

Rozhkov, A. O., Karpuk, L. M., Voropai, Y. V., Popov, S. I., Polyakov, O. I., Chigrin, O. V., Potashova, A. L., Gopenko, O. V., & Rumbakh, M. Y. (2022). Chickpea Varieties Productivity Depending on Combination of Different Sowing Methods and Sowing Rate in the Eastern Forests Steppe of Ukraine. *Ecological Engineering and Environmental Technology*, 23(1). doi: 10.12912/27197050/143140

Rudenko N. E. (2014). *Technological and Power Characteristics of Tillage Working Bodies*. Stavropol: AGRUS.

Rychel, K., Meurer, K. H. E., Börjesson, G., Strömberg, M., Getahun, G. T., Kirchmann, H., & Kätterer, T.

(2020). Deep N fertilizer placement mitigated N<sub>2</sub>O emissions in a Swedish field trial with cereals. *Nutrient Cycling in Agroecosystems*, 118(2), 133–148. doi: 10.1007/s10705-020-10089-3

Singh, M., Srivastava, R., Fuenmayor, E., Kuts, V., Qiao, Y., Murray, N., & Devine, D. (2022). Applications of Digital Twin across Industries: A Review. *Applied Sciences*, 12(11), 5727. doi: 10.3390/app12115727

Sishodia, R. P., Ray, R. L., & Singh, S. K. (2020). Applications of remote sensing in precision agriculture: A review. *Remote Sensing*, 12(19), 3136. doi: 10.3390/rs12193136

Takahashi, Y., Chinushi, T., Nagumo, Y., Nakano, T., & Ohya, T. (1991). Effect of deep placement of controlled release nitrogen fertilizer (coated urea) on growth, yield, and nitrogen fixation of soybean plants. *Soil Science and Plant Nutrition*, 37(2), 223–231. doi: 10.1080/00380768.1991.10415032

Tewari, K., Nagumo, Y., Takahashi, Y., Sueyoshi, K., Ohtake, N., & Ohya, T. (2011). A new technology of deep placement of slow release nitrogen fertilizers for promotion of soybean growth and seed yield. *Advances in Environmental Research*, 9.

Tewari, K., Sato, T., Abiko, M., Ohtake, N., Sueyoshi, K., Takahashi, Y., Nagumo, Y., Tutida, T., & Ohya, T. (2007). Analysis of the nitrogen nutrition of soybean plants with deep placement of coated urea and lime nitrogen. *Soil Science and Plant Nutrition*, 53(6), 772-781. doi: 10.1111/j.1747-0765.2007.00194.x

Walsh, M. K., Backlund, P., Buja, L., DeGaetano, A., Melnick, R., Prokopy, L., Takle, E., Todey, D., & Ziska, L. (2020). *Climate Indicators for Agriculture*. USDA Technical Bulletin. Retrieved from [https://www.usda.gov/sites/default/files/documents/climate\\_indicators\\_for\\_agriculture.pdf](https://www.usda.gov/sites/default/files/documents/climate_indicators_for_agriculture.pdf)

Wang, Y., Li, N., Ma, Y., Tong, J., Pfleging, W., & Sun, J. (2020). Field experiments evaluating a biomimetic shark-inspired (BioS) subsoiler for tillage resistance reduction. *Soil and Tillage Research*, 196, 104432. doi: 10.1016/j.still.2019.104432

Wang, Y. X., Chen, S. P., Zhang, D. X., Yang, L., Cui,

T., Jing, H. R., & Li, Y. H. (2020). Effects of subsoiling depth, period interval and combined tillage practice on soil properties and yield in the Huang-Huai-Hai Plain, China. *Journal of Integrative Agriculture*, 19(6), 1596-1608. doi: 10.1016/S2095-3119(19)62681-X

Wu, X., Li, G., Fipps, G., Zhang, F., & Yu, L. (2021). Improvement Design and Experiment of a Small Deep-placement Fertilizer Applicator. *Engineering in Agriculture, Environment and Food*, 14(3), 73-79. doi: 10.37221/EAEF.14.3\_73

Zeng, Z., Chen, Y., & Zhang, X. (2017). Modelling the interaction of a deep tillage tool with heterogeneous soil. *Computers and Electronics in Agriculture*, 143, 130–138. doi: 10.1016/J.COMPAG.2017.10.005

Zhang, N., Wang, M., & Wang, N. (2002). Precision agriculture—A worldwide overview. *Computers and Electronics in Agriculture*, 36(2–3), 113–132. doi: 10.1016/S0168-1699(02)00096-0

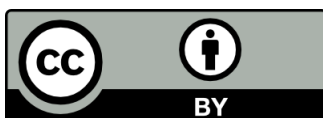

© 2023 by the authors. Licensee the future of food journal (FOFJ), Witzenhausen, Germany. This article is an open access article distributed under the terms and conditions of the Creative Commons Attribution (CC BY) license (<http://creativecommons.org/licenses/by/4.0/>).